



SEGNALATORI USURA DI PASTIGLIE E GANASCE FRENO

ALL-CABLE

PER VEICOLI INDUSTRIALI 



SEGNALATORI USURA DI PASTIGLIE E GANASCE FRENO



RIF. ALLTECH	IMPIANTO	ADATT.	
140000	ROCKWELL	IVECO	
TAMB.		EUROCARGO TECTOR CURSOR	
RIF. ORIG.	CONN.	Q.TÀ	
42539438 EX 93193778 42546123 93163583	OVALE	1	955 mm

RIF. ALLTECH	IMPIANTO	ADATT.	
140001	PERROT WABCO	FORD	
DISC.		109-14 1° SERIE IVECO EUROCARGO GAMMA Z	
RIF. ORIG.	CONN.	Q.TÀ	
1907942	TONDA	2	475 mm

RIF. ALLTECH	IMPIANTO	ADATT.	
140002	BENDIX GIRLING	IVECO	
DISC.		EUROCARGO EUROSTAR EUROTECH	
RIF. ORIG.	CONN.	Q.TÀ	
1907956	TONDA	2	300 mm

RIF. ALLTECH	IMPIANTO	ADATT.	
140003	BENDIX KNORR MERITOR	IVECO	
DISC.		EUROCARGO EUROSTAR EUROTECH	
RIF. ORIG.	CONN.	Q.TÀ	
1908231	OVALE	2	150 mm

RIF. ALLTECH	IMPIANTO	ADATT.
140004	PERROT WABCO	IVECO FORD GAMMA SU.T. 109-14 U.S. GAMMA Z-S
 DISC.		
RIF. ORIG.	CONN.	Q.TÀ
1907492	OVALE	2

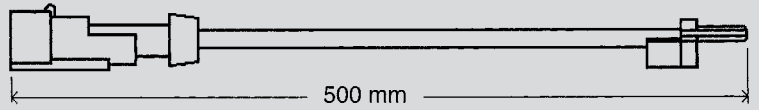

RIF. ALLTECH	IMPIANTO	ADATT.
140005	BENDIX BREMBO MERITOR	IVECO 109-14 EUROCARGO
 DISC.		
RIF. ORIG.	CONN.	Q.TÀ
1908825	TONDA	2

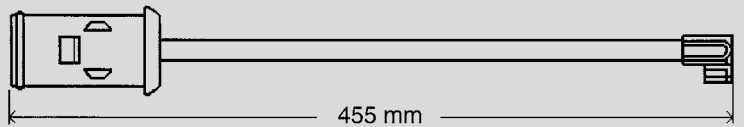

RIF. ALLTECH	IMPIANTO	ADATT.
140006	BENDIX BREMBO MERITOR	IVECO DAILY EUROCARGO
 DISC.		
RIF. ORIG.	CONN.	Q.TÀ
42548208 EX 1908407 42567357 42567660	OVALE	2

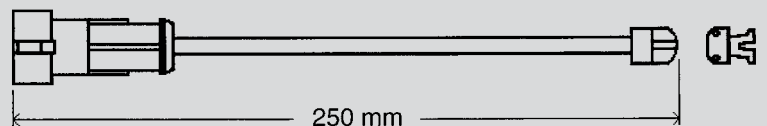

RIF. ALLTECH	IMPIANTO	ADATT.
140007	KNORR GIRLING	SCANIA MERCEDES
 DISC.		
RIF. ORIG.	CONN.	Q.TÀ
1388953	CLIPS	2

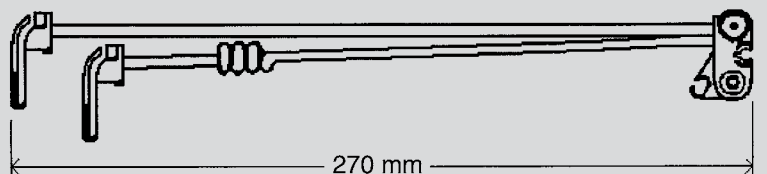

RIF. ALLTECH	IMPIANTO	ADATT.	
140008	KNORR GIRLING	SCANIA MERCEDES IVECO	<p>270 mm</p>
DISC.			
RIF. ORIG.	CONN.	Q.TÀ	<p>1300 mm</p>
1388953	CLIPS	2+2	

RIF. ALLTECH	IMPIANTO	ADATT.	
140009	KNORR BENDIX	IVECO BPW EUROCARGO	<p>270 mm</p>
DISC.			
RIF. ORIG.	CONN.	Q.TÀ	
1906468 42536956	OVALE	2	

RIF. ALLTECH	IMPIANTO	ADATT.	
140010	BENDIX BREMBO MERITOR	IVECO DAILY FORD CARGO EUROCARGO	<p>150 mm</p>
DISC.			
RIF. ORIG.	CONN.	Q.TÀ	
42548196 2992394	OVALE	2	

RIF. ALLTECH	IMPIANTO	ADATT.	
140011	PERROT WABCO	IVECO DAILY MERCEDES	<p>195 mm</p>
RIF. ORIG.	CONN.	Q.TÀ	
42530912	OVALE	2	

RIF. ALLTECH	IMPIANTO	ADATT.	
140012	BREMBO GIRLING	IVECO DAILY	
DISC.			
RIF. ORIG.	CONN.	Q.TÀ	
2991854	OVALE	2	

RIF. ALLTECH	IMPIANTO	ADATT.	
140014	AP LOCKEED	IVECO LEYLAND BEDFORD	
TAMB.			
RIF. ORIG.	CONN.	Q.TÀ	
	TONDA	2	

RIF. ALLTECH	IMPIANTO	ADATT.	
140015	PERROT WABCO	IVECO BUS 370 480 580	
TAMB.			
RIF. ORIG.	CONN.	Q.TÀ	
4802349 EX 8193412 4823690	TONDA	1	



RIF. ALLTECH	IMPIANTO	ADATT.	
140016	PERROT WABCO MERITOR	IVECO ASTRA EUROTECH EUROSTAR	
TAMB.			
RIF. ORIG.	CONN.	Q.TÀ	
42530550	OVALE	1	



RIF. ALLTECH	IMPIANTO	ADATT.	
140017	PERROT WABCO	IVECO ASTRA EUROTECH EUROSTAR	
TAMB.			
RIF. ORIG.	CONN.	Q.TÀ	
42530900	TONDA	1	

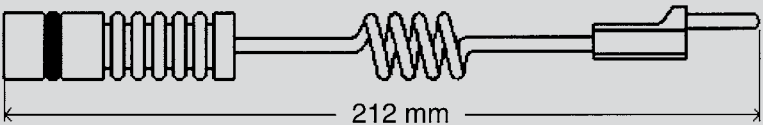

RIF. ALLTECH	IMPIANTO	ADATT.	
140018	PERROT WABCO MERITOR	IVECO ASTRA EUROCARGO EUROCLASS	
TAMB.			
RIF. ORIG.	CONN.	Q.TÀ	
42532204	OVALE	1	

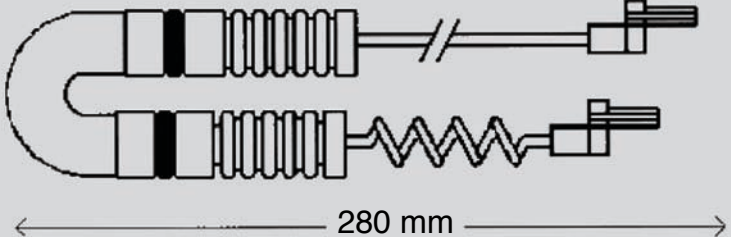

RIF. ALLTECH	IMPIANTO	ADATT.	
140019	ROCKWELL	IVECO EUROCARGO EUROSTAR	
TAMB.			
RIF. ORIG.	CONN.	Q.TÀ	
42539437 EX 93192921	OVALE	1	

RIF. ALLTECH	IMPIANTO	ADATT.	
140020	PERROT WABCO	MAN KASSBOHRER	
DISC.			
RIF. ORIG.	CONN.	Q.TÀ	
81508110004 83823884510 8285388451	TONDA	2	

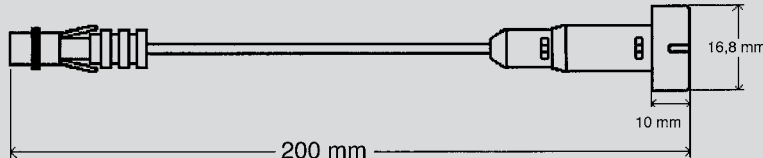
RIF. ALLTECH	IMPIANTO	ADATT.	
140021	PERROT WABCO	MERCEDES VW	
 DISC.		SPRINTER VARIO	
RIF. ORIG.	CONN.	Q.TÀ	
6695400417 9015400017 9015400117	TONDA	2	

RIF. ALLTECH	IMPIANTO	ADATT.	
140022	GIRLING LUCAS	MERCEDES OMNIBUS NEOPLAN	
 DISC.			
RIF. ORIG.	CONN.	Q.TÀ	
3565400017	TONDA	2	

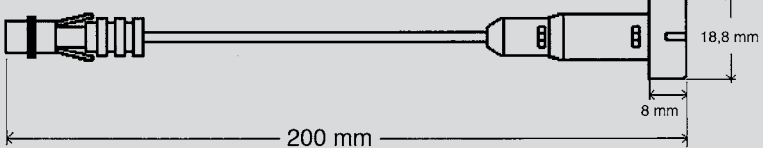
RIF. ALLTECH	IMPIANTO	ADATT.	
140023	MERCEDES	MERCEDES ACTROS	
 TAMB.		MAN TGA	
RIF. ORIG.	CONN.	Q.TÀ	
6775400817	TONDA	2	

RIF. ALLTECH	IMPIANTO	ADATT.	
140024	MERCEDES	MERCEDES ACTROS	
 TAMB.		MAN TGA F2000 F90	
RIF. ORIG.	CONN.	Q.TÀ	
6775400717	TONDA	2	

RIF. ALLTECH	IMPIANTO	ADATT.	
140025	WABCO LUCAS PAN 19	MAN F2000 F90 M2000	
DISC.			
RIF. ORIG.	CONN.	Q.TÀ	
81508226016	OVALE	2	

RIF. ALLTECH	IMPIANTO	ADATT.	
140026	MERITOR WABCO LUCAS	MAN F2000 TGA F2000 M90	
TAMB.			
RIF. ORIG.	CONN.	Q.TÀ	
81259376012	OVALE	2	

RIF. ALLTECH	IMPIANTO	ADATT.	
140027	MERITOR WABCO LUCAS	MAN F2000 F90 TGA F2000 M2000	
TAMB.			
RIF. ORIG.	CONN.	Q.TÀ	
81259376011	OVALE	2	

RIF. ALLTECH	IMPIANTO	ADATT.	
140028	MERITOR WABCO LUCAS	MERCEDES 407 410 507 510	
TAMB.			
RIF. ORIG.	CONN.	Q.TÀ	
6705400017	TONDA	2	

RIF. ALLTECH	IMPIANTO	ADATT.
140029	WABCO PAN 17	MAN L2000 M2000
DISC.		
RIF. ORIG.	CONN.	Q.TÀ
81508226014 81508226013	OVALE	2

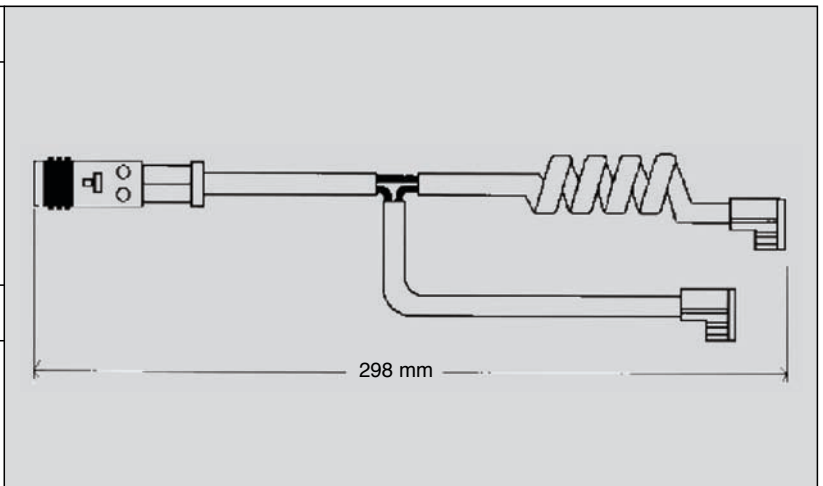

RIF. ALLTECH	IMPIANTO	ADATT.
140030	GIRLING	RVI RENAULT
DISC.		
RIF. ORIG.	CONN.	Q.TÀ
5000297198/S	PUNTALE	2

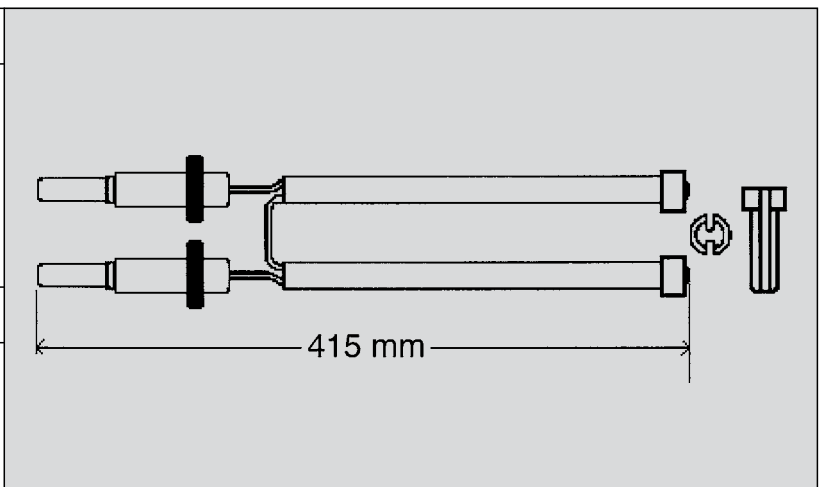

RIF. ALLTECH	IMPIANTO	ADATT.
140031	GIRLING	RVI RENAULT MAGNUM
DISC.		
RIF. ORIG.	CONN.	Q.TÀ
5001823000	OVALE	2

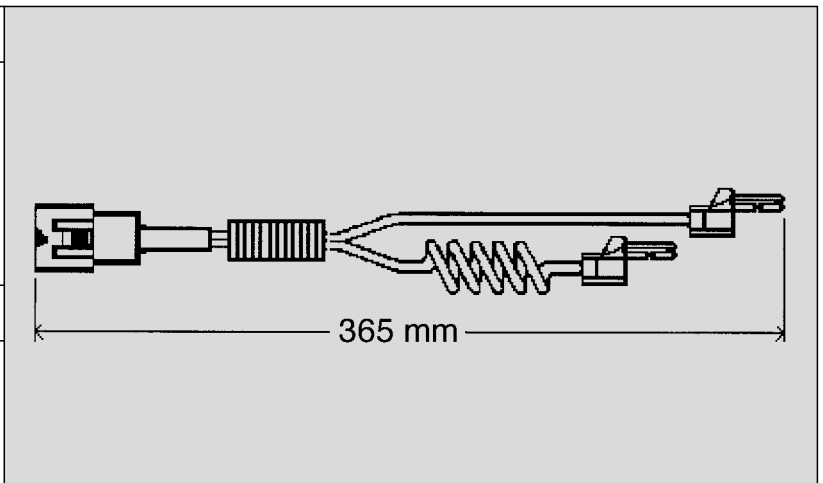

RIF. ALLTECH	IMPIANTO	ADATT.
140032	GIRLING	RVI RENAULT DAF
DISC.		
RIF. ORIG.	CONN.	Q.TÀ
68320654 2112768 1902987 1862300 1978632	OVALE	2

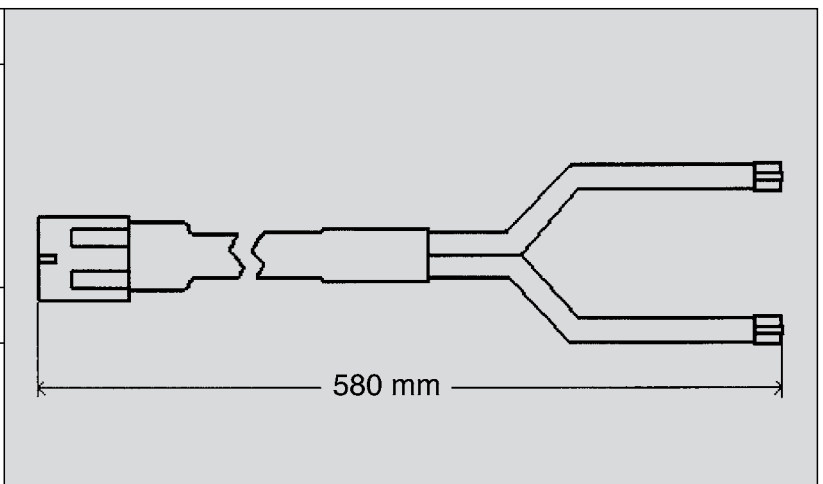

RIF. ALLTECH	IMPIANTO	ADATT.	
140033	LUCAS MERITOR D - ELSA 2	RVI RENAULT PREMIUM	
DISC.			
RIF. ORIG.	CONN.	Q.TÀ	
30018340750 A 5001855646	QUADRA	2	

RIF. ALLTECH	IMPIANTO	ADATT.	
140034	GIRLING	RVI RENAULT S120 - S180 MIDLINER	
DISC.			
RIF. ORIG.	CONN.	Q.TÀ	
68320909 68320874	OVALE	2	

RIF. ALLTECH	IMPIANTO	ADATT.	
140035	GIRLING LUCAS	RVI RENAULT MIDLINER MAGNUM MIDLUM	
DISC.			
RIF. ORIG.	CONN.	Q.TÀ	
68321348 5001831161 3118128	QUADRA	2	

RIF. ALLTECH	IMPIANTO	ADATT.	
140036	WABCO	RVI RENAULT MIDLUM	
DISC.			
RIF. ORIG.	CONN.	Q.TÀ	
5010848607	QUADRA	2	

RIF. ALLTECH	IMPIANTO	ADATT.
140037	WABCO	RVI RENAULT MIDLUM MAGNUM PREMIUM
DISC.		
RIF. ORIG.	CONN.	Q.TÀ
969900411 68324613	QUADRA	2

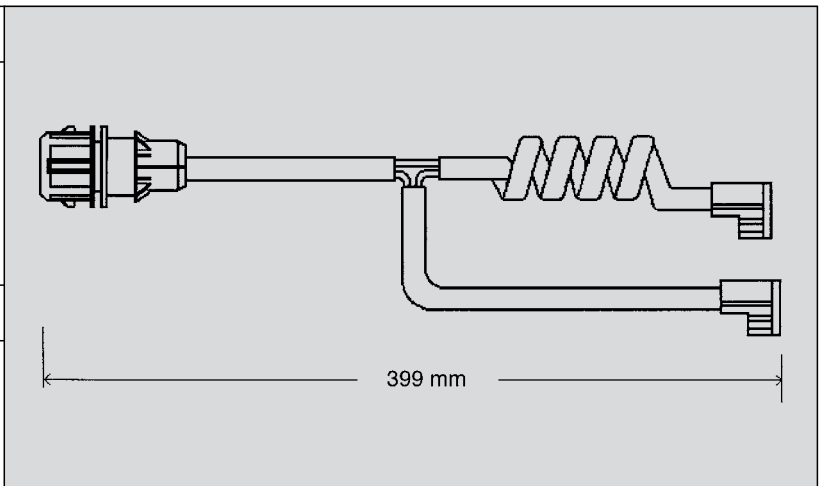

RIF. ALLTECH	IMPIANTO	ADATT.
140038	BREMBO	RVI RENAULT MASCOT NISSAN
DISC.		
RIF. ORIG.	CONN.	Q.TÀ
5001844747 5001844748 44069 - 9x400	PUNTALE	2

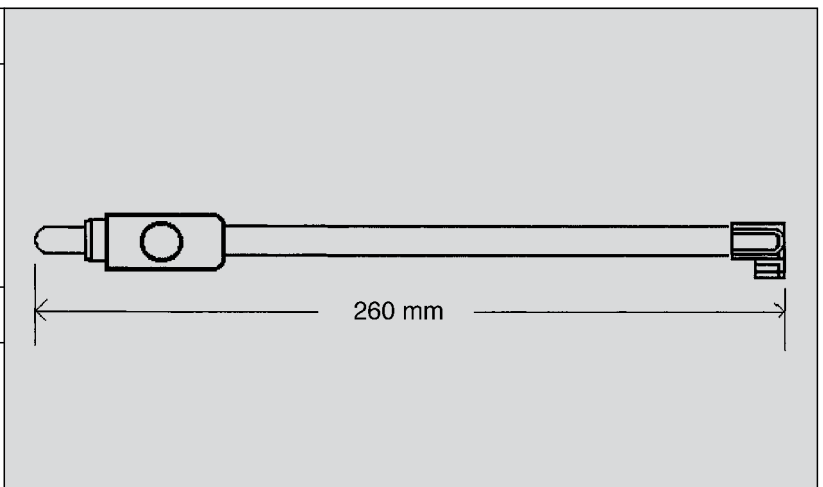

RIF. ALLTECH	IMPIANTO	ADATT.
140039	LUCAS MERITOR	RVI FORD ROR
DISC.		
RIF. ORIG.	CONN.	Q.TÀ
	QUADRA	2

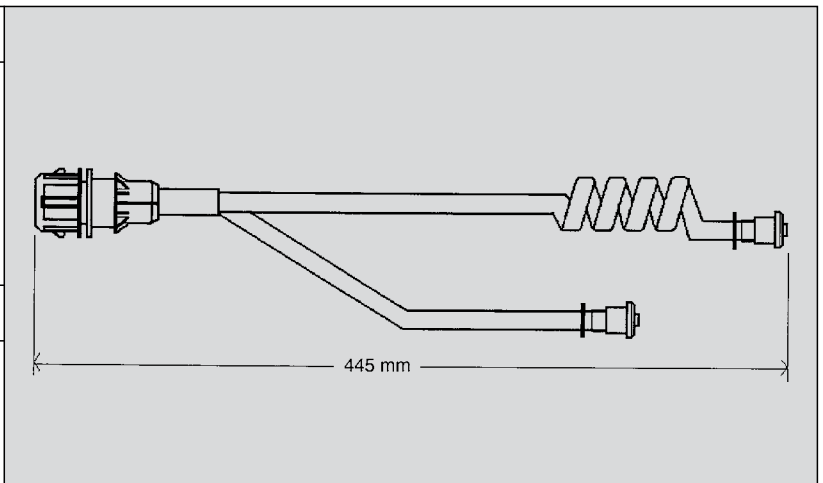

RIF. ALLTECH	IMPIANTO	ADATT.
140040	LUCAS GIRLING	VOLVO FL6
DISC.		
RIF. ORIG.	CONN.	Q.TÀ
2761476	PUNTALE	2

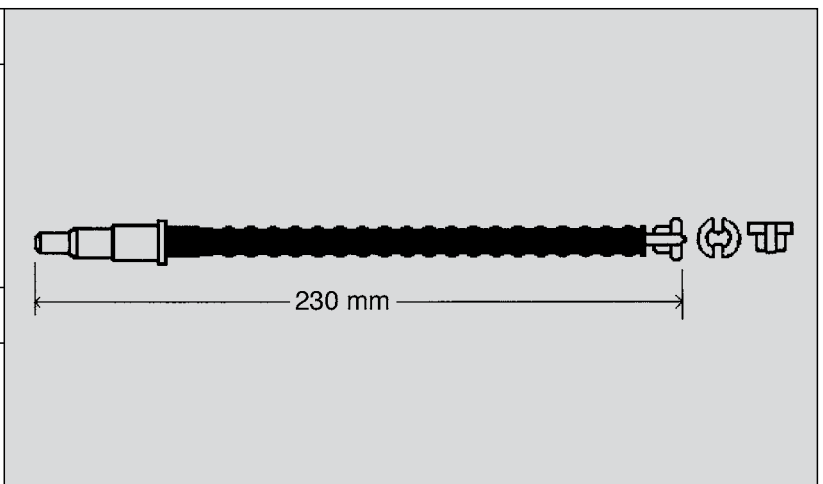

RIF. ALLTECH	IMPIANTO	ADATT.	
140041	LUCAS MERITOR	VOLVO	
DISC.			
RIF. ORIG.	CONN.	Q.TÀ	
68321484	QUADRA	2	

RIF. ALLTECH	IMPIANTO	ADATT.	
140042	VABCO	IVECO BUS	
TAMB.			
RIF. ORIG.	CONN.	Q.TÀ	
4803630	TONDO	1	

RIF. ALLTECH	IMPIANTO	ADATT.	
140044	BREBBO	MERCEDES SPRINTER VITO VW CRAFTER POST	
DISC.			
RIF. ORIG.	CONN.	Q.TÀ	
6395401417 1645401017 2E0906206G	OVALE	2	

RIF. ALLTECH	IMPIANTO	ADATT.	
140045	BREBBO	MERCEDES SPRINTER ANTERIORE VIANO VITO	
DISC.			
RIF. ORIG.	CONN.	Q.TÀ	
9065401417 2E0906206A	OVALE	2	

RIF. ALLTECH	IMPIANTO	ADATT.	
140046	BREMBO	MERCEDES SPRINTER	
DISC.			
RIF. ORIG.	CONN.	Q.TÀ	
9015400317	TONDA	2	

RIF. ALLTECH	IMPIANTO	ADATT.	
140047	BREMBO	MERCEDES SPRINTER	
DISC.			
RIF. ORIG.	CONN.	Q.TÀ	
9015400217	TONDA	2	

RIF. ALLTECH	IMPIANTO	ADATT.	
140048	BREMBO	NISSAN T.T. CABSTAR	<p style="text-align: center;">PER PASTIGLIE NISSAN 130015 - 130018 - 130032 - 130035</p>
DISC.			
RIF. ORIG.	CONN.	Q.TÀ	
MODF. ALL CABLE	OVALE	2	

RIF. ALLTECH	IMPIANTO	ADATT.	
140050	BREMBO	MENARINI BREDA BUS	
DISC.			
RIF. ORIG.	CONN.	Q.TÀ	
	TONDA	2	

RIF. ALLTECH	IMPIANTO	ADATT.	
140051	BREMBO	MENARINI BREDA BUS	
DISC.			
RIF. ORIG.	CONN.	Q.TÀ	
	TONDA	2	

RIF. ALLTECH	IMPIANTO	ADATT.	<p>PER SENSORI RIF 140011 - 140016 - 140017 - 140018</p>
140052	WABCO PERROT	IVECO ASTRA	
TAMB.			
RIF. ORIG.	CONN.	Q.TÀ	
42530551		1	

RIF. ALLTECH	IMPIANTO	ADATT.	
140053	KNORR BENDIX	IVECO EUROTECH ASTRA EUROSTAR EUROTRAKKER EUROCARGO	
DISC.			
RIF. ORIG.	CONN.	Q.TÀ	
1903651	CLIPS	2+2	

RIF. ALLTECH	IMPIANTO	ADATT.	
140054	KNORR SN7	IVECO EUROCARGO STRALIS TRAKKER EUROTECH	
DISC.			
RIF. ORIG.	CONN.	Q.TÀ	
2992666 EX 2992337	CLIPS	2	

RIF. ALLTECH	IMPIANTO	ADATT.
140055	KNORR SN7	IVECO
DISC.		EUROCARGO STRALIS DAF
RIF. ORIG.	CONN.	Q.TÀ
42537941 1448897	CLIPS	2

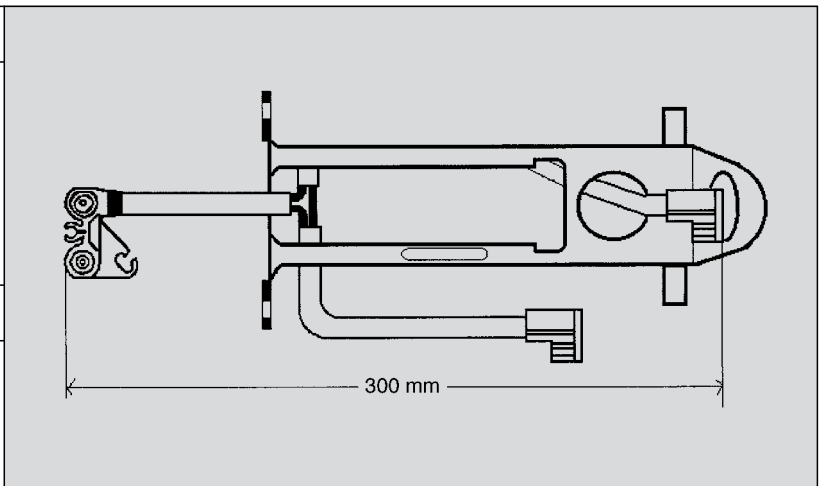

RIF. ALLTECH	IMPIANTO	ADATT.
140056	BREMBO	IVECO DAILY
DISC.		U.T.
RIF. ORIG.	CONN.	Q.TÀ
42548195 EX 2992393	OVALE	2

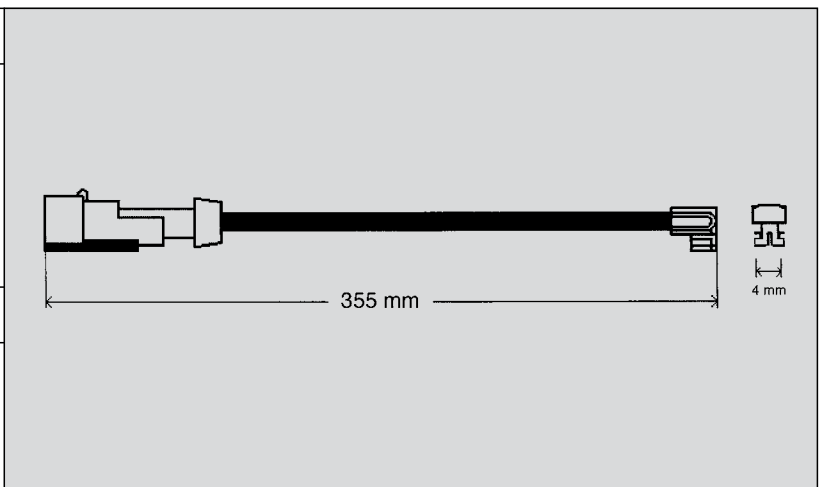

RIF. ALLTECH	IMPIANTO	ADATT.
140057	MERITOR	IVECO
TAMB.		EUROTRAKKER TECTOR
RIF. ORIG.	CONN.	Q.TÀ
42536144 42552777	OVALE	1

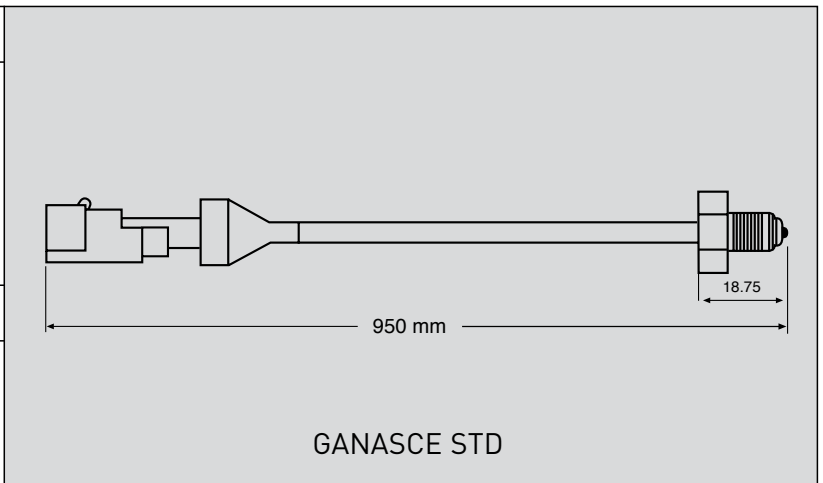

RIF. ALLTECH	IMPIANTO	ADATT.
140058	MERITOR	IVECO
TAMB.		EUROTRAKKER TECTOR
RIF. ORIG.	CONN.	Q.TÀ
42552779 EX 42537728	OVALE	1

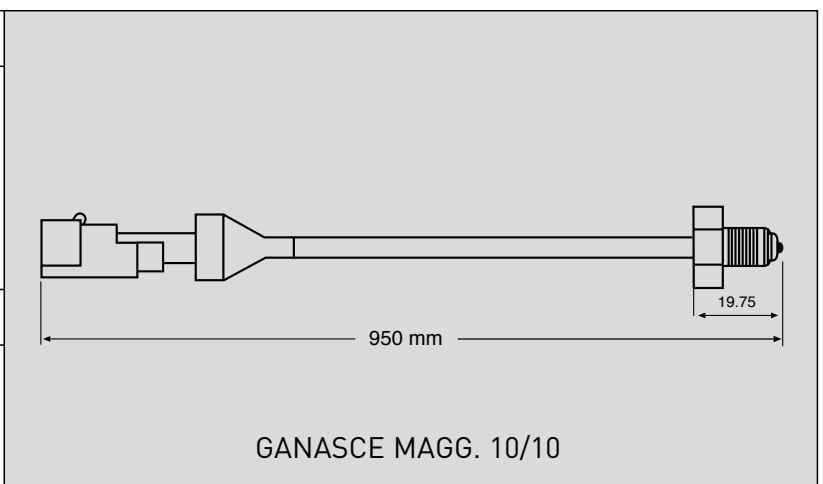

RIF. ALLTECH	IMPIANTO	ADATT.	
140059	MERITOR	IVECO EUROTRAKKER TECTOR	<p style="text-align: center;">950 mm</p> <p style="text-align: right;">20.75</p> <p style="text-align: center;">GANASCE MAGG. 20/10</p>
TAMB.			
RIF. ORIG.	CONN.	Q.TÀ	
42537729	OVALE	1	

RIF. ALLTECH	IMPIANTO	ADATT.	
140060	WABCO PAN 17	DAF LEYLAND LF45-FA45-170	<p style="text-align: center;">330 mm</p>
DISC.			
RIF. ORIG.	CONN.	Q.TÀ	
	OVALE	2	

RIF. ALLTECH	IMPIANTO	ADATT.	
140061	WABCO PAN 17	DAF LEYLAND LF45-FA45	<p style="text-align: center;">330 mm</p>
DISC.			
RIF. ORIG.	CONN.	Q.TÀ	
	OVALE	2	

RIF. ALLTECH	IMPIANTO	ADATT.	
140062	KNORR WABCO HALDEX	IVECO MAN DAF ROR BPW	
DISC.			
RIF. ORIG.	CONN.	Q.TÀ	
	OVALE	1	

RIF. ALLTECH	IMPIANTO	ADATT.
140064	MERITOR	IVECO TRAKKER
 TAMB.		
RIF. ORIG.	CONN.	Q.TÀ
42550958 2997533	OVALE	1

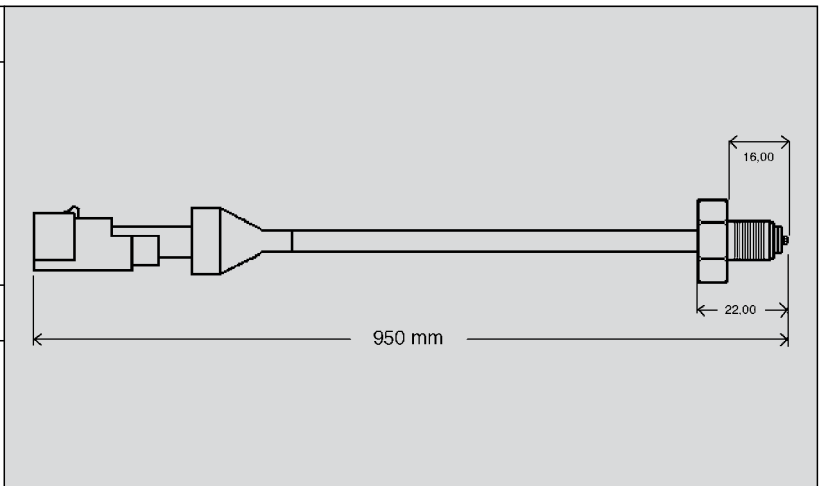

RIF. ALLTECH	IMPIANTO	ADATT.
140070	WABCO	IVECO TECTOR CURSOR
 DISC.		
RIF. ORIG.	CONN.	Q.TÀ
42536956 1906468	OVALE	2

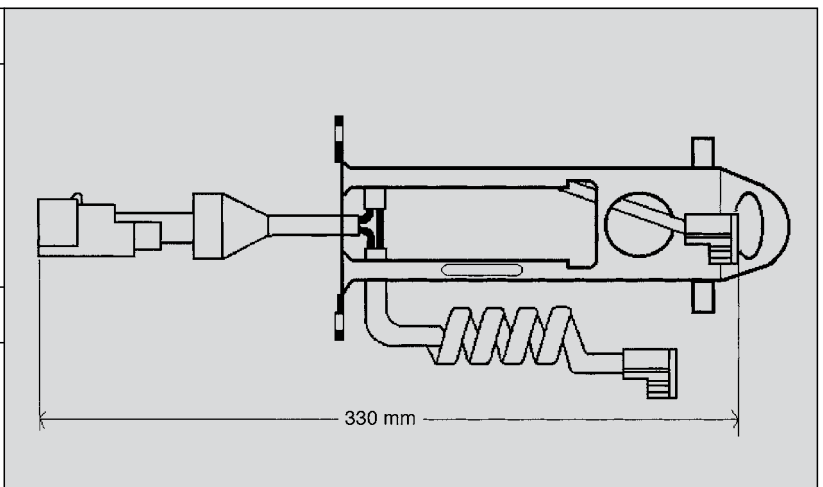

RIF. ALLTECH	IMPIANTO	ADATT.
140071	WABCO	IVECO TECTOR CURSOR
 DISC.		
RIF. ORIG.	CONN.	Q.TÀ
1906468 42536956	OVALE	2

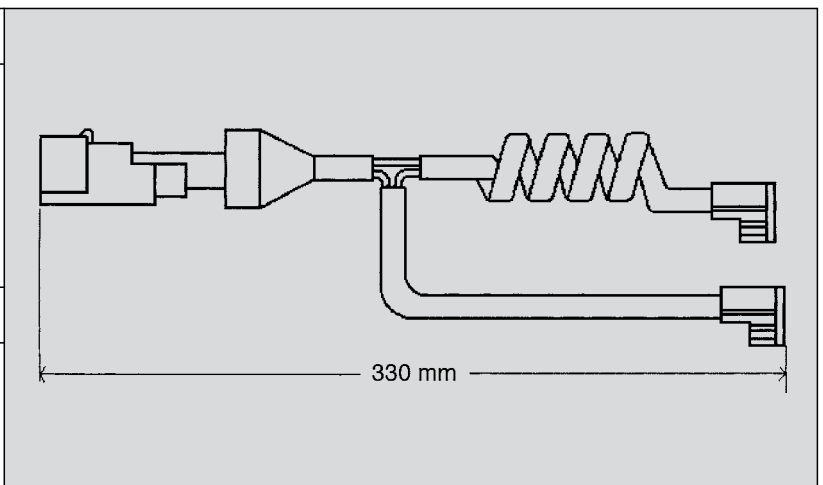

RIF. ALLTECH	IMPIANTO	ADATT.
140072	BREMBO	IVECO 65C13 DAILY ANT.
 DISC.		
RIF. ORIG.	CONN.	Q.TÀ
42555634 500054694	OVALE	2

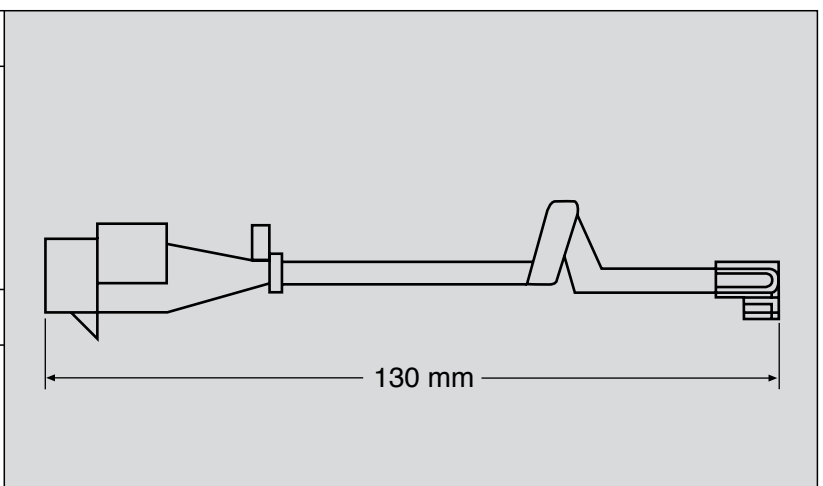

RIF. ALLTECH	IMPIANTO	ADATT.	
140073	BREMBO	IVECO 65C13 DAILY U.T. POST.	
DISC.			
RIF. ORIG.	CONN.	Q.TÀ	
42556205 500054695 42567354 5801486732	OVALE	2	

RIF. ALLTECH	IMPIANTO	ADATT.	
140074	BREMBO	IVECO	
DISC.			
RIF. ORIG.	CONN.	Q.TÀ	
42560913 EX 42559191 500054693	OVALE	2	

RIF. ALLTECH	IMPIANTO	ADATT.	
140077	BREMBO	IVECO EUROCARGO	
DISC.			
RIF. ORIG.	CONN.	Q.TÀ	
500054696 42559616 2992394 42567355 5801486731	OVALE	2	

RIF. ALLTECH	IMPIANTO	ADATT.	
140080	BENDIX KNORR	IVECO APPLIC. VARIE	
DISC.			
RIF. ORIG.	CONN.	Q.TÀ	
	OVALE	2	

RIF. ALLTECH	IMPIANTO	ADATT.
140081	WABCO KNORR	MAN M2000
 DISC.		
RIF. ORIG.	CONN.	Q.TÀ
81508226015 81508226029	OVALE	2

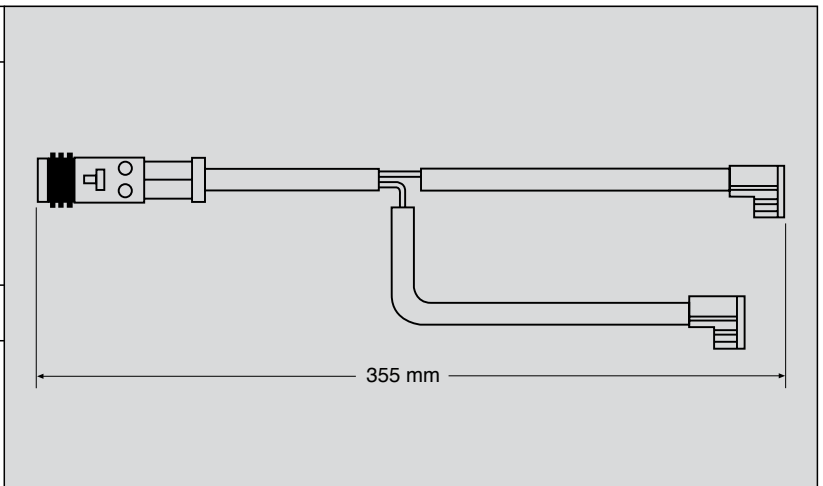

RIF. ALLTECH	IMPIANTO	ADATT.
140090	WABCO KNORR	MAN NEOPLAN DAF
 DISC.		
RIF. ORIG.	CONN.	Q.TÀ
68323004	OVALE	2+2

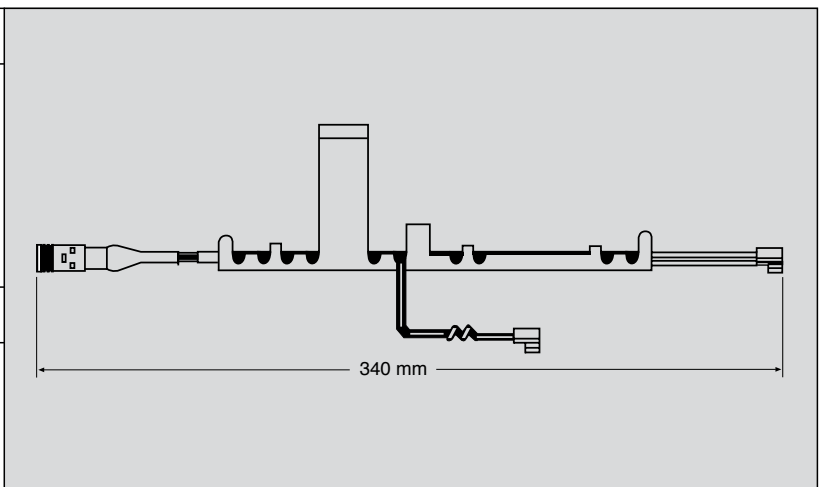

RIF. ALLTECH	IMPIANTO	ADATT.
140091	MERITOR	RVI SAF. RENAULT IVECO
 DISC.		
RIF. ORIG.	CONN.	Q.TÀ
69325974	QUADRA	2+2

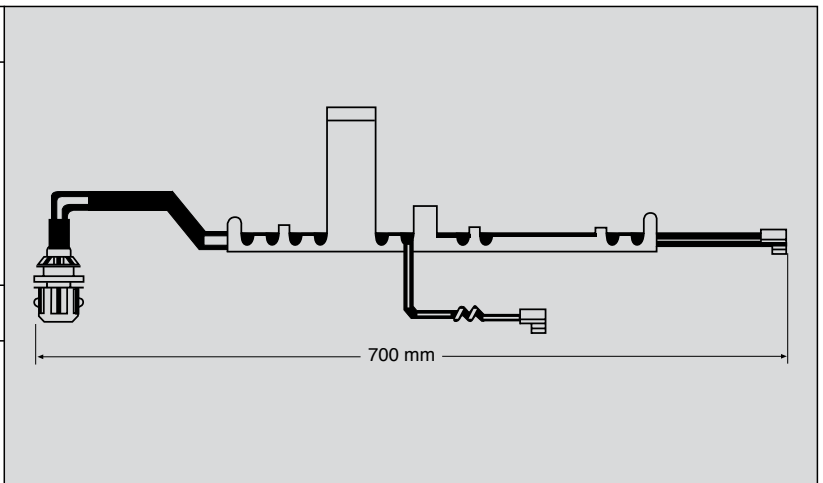

RIF. ALLTECH	IMPIANTO	ADATT.
140092	MERITOR LUCAS	RENAULT DAF MAGNUM MIDLUM
 DISC.		
RIF. ORIG.	CONN.	Q.TÀ
969900275 68324613	QUADRA	2

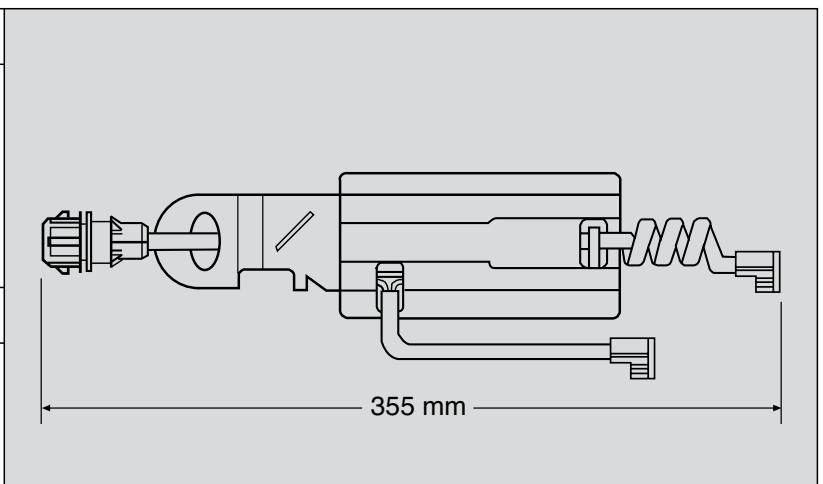

RIF. ALLTECH	IMPIANTO	ADATT.	
140093	MERITOR LUCAS	RENAULT FORD DAF	
DISC.			
RIF. ORIG.	CONN.	Q.TÀ	
	QUADRA	2	

RIF. ALLTECH	IMPIANTO	ADATT.	
140095	PERROT WABCO	MAN MERCEDES	
DISC.			
RIF. ORIG.	CONN.	Q.TÀ	
36259376009 0035426818	TONDA	2+2	

RIF. ALLTECH	IMPIANTO	ADATT.	
140098	MERITOR	RVI RENAULT SCANIA ASSALI SAF VOLVO	
DISC.			
RIF. ORIG.	CONN.	Q.TÀ	
68325408 EX 5001864363 85110419	QUADRA	2+2	

RIF. ALLTECH	IMPIANTO	ADATT.	
140099	MERITOR	ASSALI SAF SCANIA RVI RENAULT	
DISC.			
RIF. ORIG.	CONN.	Q.TÀ	
	QUADRA	2+2	

RIF. ALLTECH	IMPIANTO	ADATT.	
140100	ROR MERITOR	ROR ASSALI	
DISC.			
RIF. ORIG.	CONN.	Q.TÀ	
	OVALE	2	

RIF. ALLTECH	IMPIANTO	ADATT.	
140101	MERITOR	RENAULT	
DISC.			
RIF. ORIG.	CONN.	Q.TÀ	
5001855646	QUADRA	2	

RIF. ALLTECH	IMPIANTO	ADATT.	
140102	MERITOR	IVECO -BUS	
TAMB.			
RIF. ORIG.	CONN.	Q.TÀ	
42539439		1	

RIF. ALLTECH	IMPIANTO	ADATT.	
140103	MERITOR	ASSALI R.O.R. RENAULT	
DISC.			
RIF. ORIG.	CONN.	Q.TÀ	
30018340750	QUADRA	2	

RIF. ALLTECH	IMPIANTO	ADATT.	
140104	MERITOR	RENAULT MAN	
DISC.			
RIF. ORIG.	CONN.	Q.TÀ	
		1	

RIF. ALLTECH	IMPIANTO	ADATT.	
140105	WABCO PERROT	IVECO BUS	
TAMB.			
RIF. ORIG.	CONN.	Q.TÀ	
42531660		1	

RIF. ALLTECH	IMPIANTO	ADATT.	
140106	MERITOR	MAN TGA F2000	
DISC.			
RIF. ORIG.	CONN.	Q.TÀ	
68324072	OVALE	2	

RIF. ALLTECH	IMPIANTO	ADATT.	
140107	MERITOR	BREDA MENARINI BUS	
DISC.			
RIF. ORIG.	CONN.	Q.TÀ	
02544625 MDP 5083	QUADRA	2	

RIF. ALLTECH	IMPIANTO	ADATT.
140108	MERITOR	RVI SAF MAN
DISC.		
RIF. ORIG.	CONN.	Q.TÀ
		1

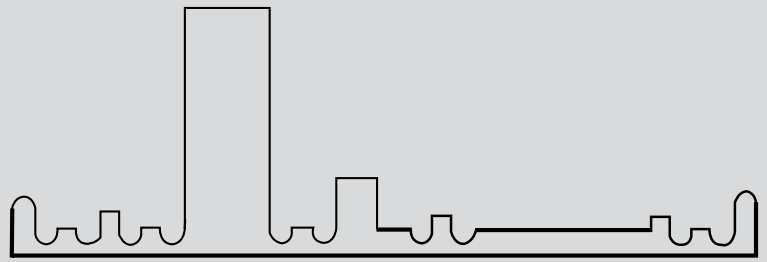

RIF. ALLTECH	IMPIANTO	ADATT.
140109	WABCO	MAN
DISC.		
RIF. ORIG.	CONN.	Q.TÀ
	OVALE	2

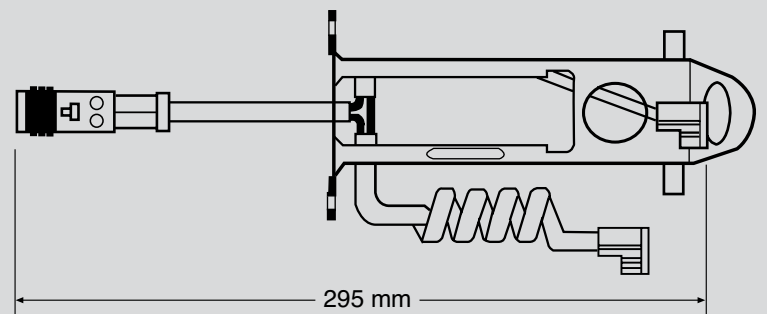

RIF. ALLTECH	IMPIANTO	ADATT.
140110	KNORR	BPW
DISC.		
RIF. ORIG.	CONN.	Q.TÀ
		1

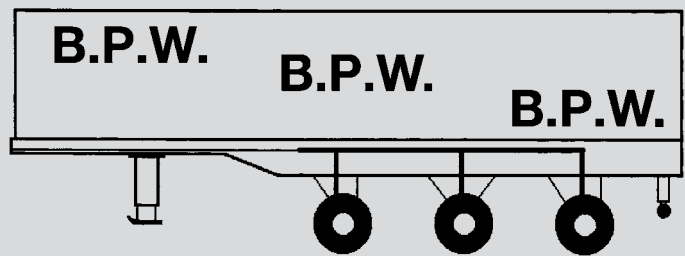

* 1 centralina - 1 cablaggio - 3 kit sensori usura

RIF. ALLTECH	IMPIANTO	ADATT.
140115	HALDEX	RENAULT VOLVO
DISC.		
RIF. ORIG.	CONN.	Q.TÀ
5010598372 20780788	QUADRA	2+2

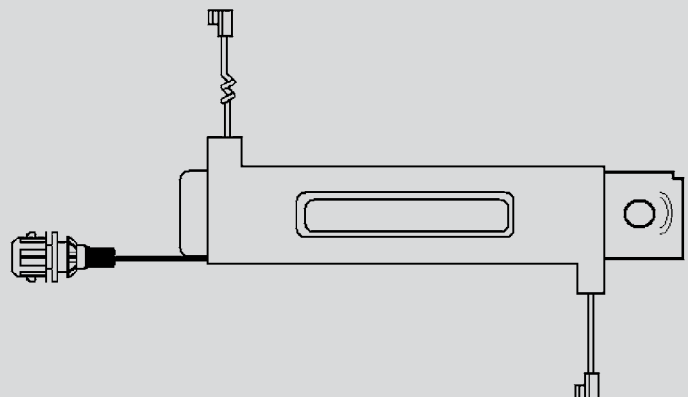

RIF. ALLTECH	IMPIANTO	ADATT.	
140120	ROR MERITOR	ROR	
DISC.			
RIF. ORIG.	CONN.	Q.TÀ	
		1	

* 1 centralina - 1 cablaggio - 3 kit sensori usura

RIF. ALLTECH	IMPIANTO	ADATT.	
140121	HALDEX WABCO KNORR	BPW SAF SMB	
DISC.			
RIF. ORIG.	CONN.	Q.TÀ	
Z0008241 3424200600	TONDA	2	

RIF. ALLTECH	IMPIANTO	ADATT.	
140122	HALDEX WABCO	SCANIA DAF VOLVO SAF	
DISC.			
RIF. ORIG.	CONN.	Q.TÀ	
Z0008242 3424203300	TONDA	2	

RIF. ALLTECH	IMPIANTO	ADATT.	
140123	HALDEX WABCO KNORR	IVECO MAN DAF ROR BPW	
DISC.			
RIF. ORIG.	CONN.	Q.TÀ	
		1	

RIF. ALLTECH	IMPIANTO	ADATT.
140124	MERITOR	ROR SAF RENAULT
DISC.		
RIF. ORIG.	CONN.	Q.TÀ
		2

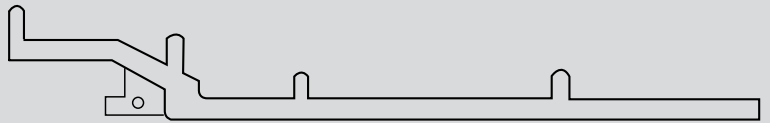

RIF. ALLTECH	IMPIANTO	ADATT.
140125	KNORR WABCO HALDEX	TRAILER ASSALI BPW SAF SMB
DISC.		
RIF. ORIG.	CONN.	Q.TÀ
	TONDA	2

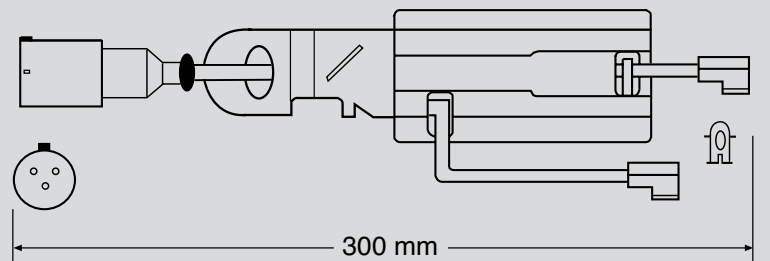

RIF. ALLTECH	IMPIANTO	ADATT.
140126	KNORR WABCO HALDEX	TRAILER ASSALI BPW SAF SMB
DISC.		
RIF. ORIG.	CONN.	Q.TÀ
124800036 3424200100	TONDA	2

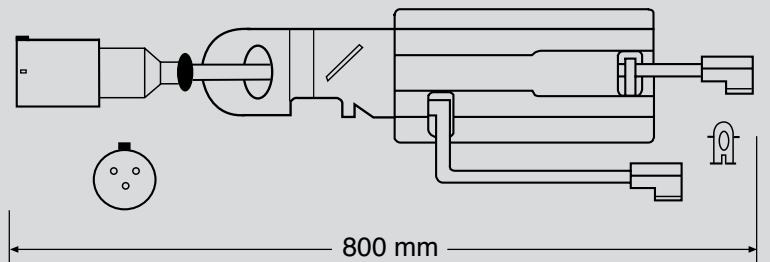

RIF. ALLTECH	IMPIANTO	ADATT.
140127	MERITOR	RENAULT MIDLUM
DISC.		
RIF. ORIG.	CONN.	Q.TÀ
5010848607	QUADRA	2+2

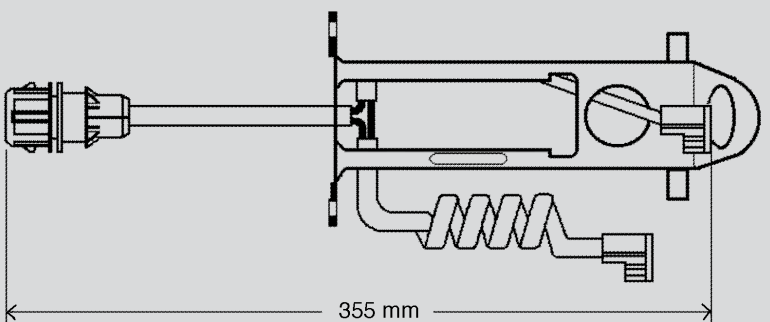

RIF. ALLTECH	IMPIANTO	ADATT.	
140130	MERITOR KNORR WABCO	TRAILER ROR	
DISC.			
RIF. ORIG.	CONN.	Q.TÀ	
MBA1152	TONDA	2+2	

RIF. ALLTECH	IMPIANTO	ADATT.	
140132	KNORR	MERCEDES SB700	
DISC.			
RIF. ORIG.	CONN.	Q.TÀ	
4253805	TONDA	2+2	

RIF. ALLTECH	IMPIANTO	ADATT.	
140133		SUPPORTO METALLICO	
DISC.			
RIF. ORIG.	CONN.	Q.TÀ	

RIF. ALLTECH	IMPIANTO	ADATT.	
140135	KNORR	MERCEDES ACTROS	
DISC.			
RIF. ORIG.	CONN.	Q.TÀ	
A0064201520 A0064205320	TONDA	2+2	

RIF. ALLTECH	IMPIANTO	ADATT.
140140		ROR
 DISC.		
RIF. ORIG.	CONN.	Q.TÀ
B1003016000A	QUADRA	2

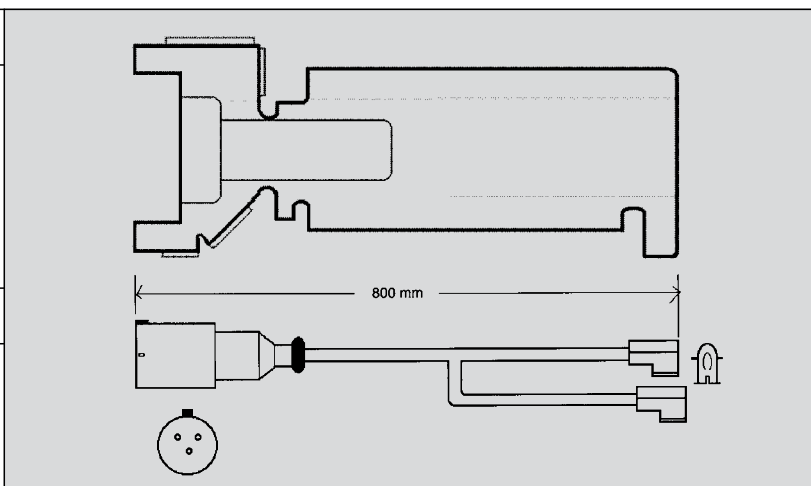

PADS - CONTROL

**L'INDICATORE DI USURA DELLE PASTIGLIE
PER RIMORCHI E SEMIRIMORCHI
RIF. ALLTECH 140110 B.P.W. e 140120 R.O.R.**



Il sistema permette di segnalare il consumo delle pastiglie freno dei rimorchi e semirimorchi, prima di avere danneggiato in modo irreparabile i dischi freno, o peggio ancora le pinze freno.

Tramite un segnale luminoso, il sistema avverte in tempo quando è giunto il momento per la sostituzione delle pastiglie freno. Il sistema si installa in modo rapido, e non richiede lavorazioni meccaniche; si adatta perfettamente ai vari tipi di assali esistenti.



RIF. ALLTECH	RIF. ORIG.	APPLICAZIONI	
180000	29042 - 29061 29087 - 29105 29106 - 29108 29109 - 29163 29167 - 29179	KNORR BREMSE	
PADS	29171		
130001 130002 130005 130006 130009 130040 130082	29093 - 29094 29095 - 29096 29145 - 29165 29184 - 29187 29158 29115 - 29116 29148 - 29183		

RIF. ALLTECH	RIF. ORIG.	APPLICAZIONI	
180001	29119 - 29141 29126 - 29156 29159	DAF DENNIS MERCEDES RENAULT SAF SMB VOLVO WABCO	
PADS			
130003			

RIF. ALLTECH	RIF. ORIG.	APPLICAZIONI	
180002	29120 - 29185 29147	TRAILERS HALDEX SAF SCANIA SMB	
PADS			
130004 130008 130049			

RIF. ALLTECH	RIF. ORIG.	APPLICAZIONI	
180003	29149	MERITOR	
PADS			
130007			

RIF. ALLTECH	RIF. ORIG.	APPLICAZIONI	
180004	29229	IVECO DAILY	
	29230		
	29232		
PADS			
130015 130016			

RIF. ALLTECH	RIF. ORIG.	APPLICAZIONI	
180005	29123	IVECO DAILY FIAT DUCATO	
	23917		
	23918		
PADS			
130019 130047			

RIF. ALLTECH	RIF. ORIG.	APPLICAZIONI	
180006	29147	RENAULT VOLVO	
	29181		
	29187		
PADS	29195		
130049	29207		

RIF. ALLTECH	RIF. ORIG.	APPLICAZIONI	
180007	29074	IVECO BUS	
	29075		
	29186		
PADS			
130051			

RIF. ALLTECH	RIF. ORIG.	APPLICAZIONI	
180008	29099 - 29100	MERITOR NISSAN RENAULT	
PADS	130059 130060		

RIF. ALLTECH	RIF. ORIG.	APPLICAZIONI	
180009	8971686330 8971686340	ISUZU	
PADS	130062 130063		

RIF. ALLTECH	RIF. ORIG.	APPLICAZIONI	
180010	29088	IVECO DAF RENAULT	
PADS	130123		

RIF. ALLTECH	RIF. ORIG.	APPLICAZIONI	
180011	29169 - 29173 29177	MERITOR	
PADS	130074		

RIF. ALLTECH	RIF. ORIG.	APPLICAZIONI	
180012	29030 - 29083 29084 - 29113 29114	DENNIS KASSBOHRER MAN MERCEDES MERITOR RENAULT	
PADS	29131		
130077 130076			

RIF. ALLTECH	RIF. ORIG.	APPLICAZIONI	
180013	29151 29125	MERITOR VOLVO	
PADS			
130083 130121			

RIF. ALLTECH	RIF. ORIG.	APPLICAZIONI	
180014	29090	DENNIS PSV MERITOR RENAULT VOLVO	
PADS			
130116			

RIF. ALLTECH	RIF. ORIG.	APPLICAZIONI	
180015	29124 29150	MENARINI MERITOR	
PADS			
130117 130118			

RIF. ALLTECH	RIF. ORIG.	APPLICAZIONI	
180016	29076 29153	MERCEDES VW	
PADS 130122			

RIF. ALLTECH	RIF. ORIG.	APPLICAZIONI	
180017	29162	SAF	
PADS 130073			



www.alltechsrl.com



Contatti



ALLTECH S.r.l.
Via G. Vasino 7
10023 Chieri (TO) - Italy

Tel: +39 0119473467
Fax: +39 0119473468
alltech@alltechsrl.com
www.alltechsrl.com

P.IVA: 06499940010